

# Hardware Architecture for Nanorobot Application in Cerebral Aneurysm

Adriano Cavalcanti<sup>1,2,\*</sup>, Bijan Shirinzadeh<sup>1</sup>, Toshio Fukuda<sup>3</sup>, and Seiichi Ikeda<sup>3</sup>

<sup>1</sup>*Robotics and Mechatronics Research Lab, Dept. of Mechanical Eng., Monash University, Australia*

<sup>2</sup>*Computational Nanomechatronics Lab, CAN Center for Automation in Nanobiotech, Brazil*

<sup>3</sup>*Dept. of Micro-Nano Systems Eng., Nagoya University, Japan*

**Abstract** — This paper presents an innovative hardware architecture for medical use of nanorobots proposed as an advanced and precise tool for brain aneurysm instrumentation and diagnosis. The feasibility of the outlined architecture is supported by nanobioelectronics, clinical data, and wireless technologies, as embedded integrated system devices for molecular machine data transmission and control upload. The upcoming therapeutic possibility of using nanorobots for aneurysm treatments is the natural result from some recent developments and trends in nanoelectronics, wireless communication, remote power transmission, quantum dots, nanotubes, SOI, lithography, biomedical instrumentation, genome mapping, and photonics. To illustrate the proposed approach, we applied advanced 3D simulation techniques as a practical choice on methodology for medical nanorobotics architecture and integrated system prototyping.

**Keywords** — *Architecture, DNA molecular machine, CMOS integrated circuits, medical nanorobotics, nanobioelectronics, nanomechatronics.*

## I. INTRODUCTION

Endovascular treatment of brain aneurysms, arteriovenous malformations, and arteriovenous fistulas are biomedical problems expected to benefit from current research and developments in the field medical nanorobotics [1]. The advent of biomolecular science and new manufacturing techniques is advancing the miniaturization of devices from micro to nanobioelectronics [2]. A first series of nanotechnology prototypes for molecular machines are being investigated in different ways [3], [4], [5], [6], and some interesting device propulsion and sensing approaches have been presented [7], [8], [9]. More complex molecular machines, or nanorobots, having embedded nanoscopic features represent new tools for medical procedures [10], [11]. Sensors for biomedical applications are advancing through tele-operated surgery and pervasive medicine [12], and this same technology provides the basis for manufacturing biomolecular actuators.

The application of medical nanorobots for brain aneurysm is presented in this work. Therefore, the paper describes main parameters used for the medical nanorobot architecture prototyping and its control activation, as well as the required technologies that address the manufacturing hardware background for molecular machines. For analysis, a real time simulation based on clinical data is implemented, demonstrating sensor and nanorobot behavior capabilities for detection of abnormal vessel dilatation in cases of cerebral

aneurysm [13].

The use of real time 3D prototyping and simulation are important tools for medical nanorobots research and development [2]. Such tools have significantly helped the semiconductor industry to achieve faster VLSI development [14]. It may have similarly direct impact on the implementation of nanomanufacturing techniques and also on nanoelectronics progress [15]. Simulation can anticipate performance, help in device modelling, manufacturing analysis, nanomechatronics control investigation, and hardware design [16].

## II. NANOROBOT FOR INTRACRANIAL THERAPY

Considering the properties of nanorobots to navigate as bloodborne devices, they can help on important treatment processes of complex diseases in early diagnosis and smart drug delivery [10], [17]. Their application on different tasks can be performed through embedded nanosensors to identify medical targets inside the human body.

Numerical analysis and advanced computational simulation techniques are used to investigate nanorobot interaction and activation for sensing gradient changes of relevant chemical patterns for brain aneurysm. Thus, a detailed approach is described serving as a testbed to support the fast development of molecular machines towards new therapies and treatments. An important and interesting aspect in the current development is the fact that, the similar hardware architecture and sensing methodology presented for nanorobots to identify intracranial harmful vessel growth, can also be used for a broad range of problems in medicine, including specialized brain therapies, neurodegenerative problems, and surgery [1], [18].

A key factor to increase the changes for patients in having a satisfactory treatment from cerebral aneurysm relies on detection of vessel deformation in early stages of bulbs development, and nanorobots are used for this task in our study.

## III. NANOROBOT HARDWARE ARCHITECTURE

The use of microdevices for medical treatments and instrumentation is a reality which has brought many improvements in clinical procedures in recent years. For example, catheterization has been used as an important methodology for aneurysm surgery [13], [19]. In the same way as the development of microtechnology in the 1980s has led to

---

*This project was partially funded by the Australian Research Council (ARC).*

*\*Contact author: [adrianocavalcanti@canbiotechnems.com](mailto:adrianocavalcanti@canbiotechnems.com).*

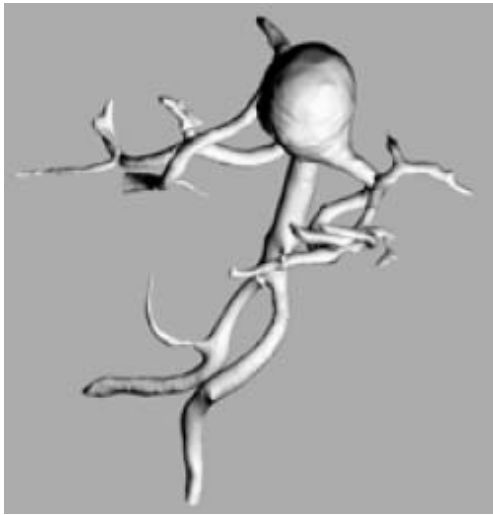

Fig. 1: Basilar artery with aneurysm - 3D structure based on CT Computer Tomography angiography.

new tools for surgery, emerging nanotechnologies will similarly permit further advances providing better diagnosis and new devices for medicine through the manufacturing of nanoelectronics [15].

The main parameters used for the medical nanorobot architecture and its control activation, as well as the required technology background to advance manufacturing hardware for molecular machines, are described next.

#### A. Manufacturing Technology

The ability to manufacture nanorobots can be understood as the result from current trends and new methodologies in fabrication, computation, transducers and manipulation. Depending on the case, different gradients on temperature, concentration of chemicals in the bloodstream, and electromagnetic signature are some of relevant parameters for biomedical purposes. The CMOS industry is successfully showing a pathway for the assembly processes needed to manufacture components required to enable nanorobots, where the joint use of nanophotonic and nanotubes is even accelerating further the actual levels of resolution ranging from 248nm to 157nm devices [16]. To validate designs and to achieve a successful implementation, the use of VHDL has become the most common methodology utilized in the integrated circuit manufacturing industry [20].

#### B. Chemical Sensor

CMOS integrated sensors using nanowires as material for circuit assembly can achieve maximal efficiency for applications regarding chemical changes, enabling new medical applications [21]. Sensors with suspended arrays of nanowires assembled into silicon circuits decrease drastically self-heating and thermal coupling for CMOS functionality [22]. To further advance manufacturing techniques, Silicon-On-Insulator (SOI) technology has been used to assemble high-performance logic sub 90nm circuits [16]. Circuit design approaches to solve problems with bipolar effect and hysteretic

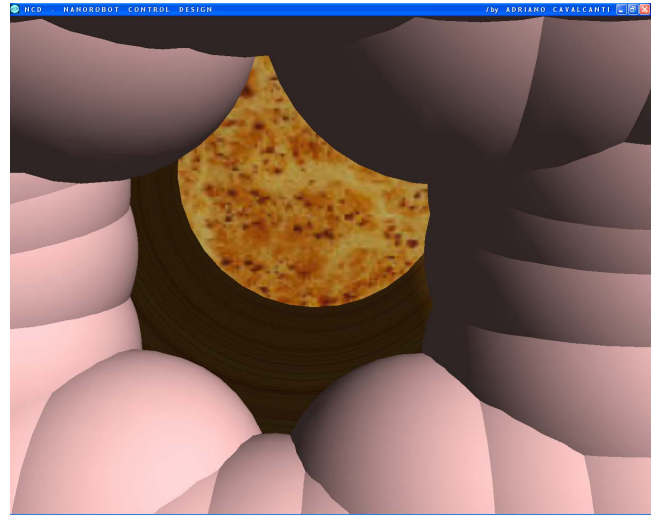

Fig. 2: Aneurysm in initial stages of development - 3D Model.

variations based on SOI structures has been demonstrated successfully [23]. Thus, already-feasible 90nm and 45nm NanoCMOS IC represent breakthrough technology devices that are already being utilized in products.

The human genome mapping showed from chromosome 12 [24] that the protein Nitric Oxide Synthase (NOS) can provide positive or negative effects upon cell and tissues in their cellular living processes. It was also established the correlations between higher levels of NOS and brain aneurysm (Fig. 1) were established [25]. In the nanorobot model the antibody CAB002167 is used for modeling the IC sensor; the antibody serves to identify higher concentrations of proteins that couple NOS isoforms to intracellular bloodstream signaling [26]. The nanobiosensor provides an efficient integrated way for nanorobots identifying the locations with occurrences of NOS, which in such case is denoted by changes of gradients in the brain enzymes. Carbon nanotubes serve as ideal materials for the basis of a CMOS IC nanobiosensor.

#### C. Actuator

A set of fullerene structures were presented for nanoactuators [27]. The use of CNTs as conductive structures permits electrostatically driven motions providing forces necessary for nanomanipulation. CNT selfassembly and SOI properties can be combined to addressing CMOS high performance on design and manufacturing nanoelectronics and nanoactuators [28]. Owing to the maturity of silicon CMOS technology, as well as the unique properties of CNTs, the integration of CNT and the CMOS technology makes use of the advantages of both.

For a medical nanorobot, the use of CMOS as an actuator based on biological patterns and CNTs is adopted in our architecture as a natural choice. In the same way DNA can be used for coupling energy transfer [29], [30], and proteins may serve as basis for ionic flux with electrical discharge ranges from 50-70 mV dc voltage gradients in cell membrane [31], an array format based on CNTs and CMOS techniques can be used to achieve nanomanipulators as an embedded system for integrating nanodevices of molecular machines [32]. Ion



Fig. 3: Aneurysm morphology - MCA Middle Cerebral Artery, BT Basilar Trunk, and BA Basilar Artery.

channels can interface electrochemical signals using sodium for the energy generation which is necessary for mechanical actuators operation [31]. Embedded actuators are programmed to perform different manipulations, enabling the nanorobot a direct active interaction with the bloodstream patterns and the molecular parameters inside the body.

D. Power Supply

The use of CMOS for active telemetry and power supply is the most effective and secure way to ensure energy as long as necessary to keep the nanorobot in operation. The same technique is also appropriate for other purposes like digital bit encoded data transfer from inside a human body [33]. Thus nanocircuits with resonant electric properties can operate as a chip providing electromagnetic energy supplying 1.7 mA at 3.3V for power, allowing the operation of many tasks with few or no significant losses during transmission [34]. RF-based telemetry procedures have demonstrated good results in patient monitoring and power transmission with the use of inductive coupling [35], using well established techniques already widely used in commercial applications of RFID - Radio Frequency Identification Device. The energy received can be also saved in ranges of  $\sim 1\mu W$  while the nanorobot stays in inactive modes, just becoming active when signal patterns require it to do so.

E. Data Transmission

Using integrated sensor for data transfer is the best answer to read and write data in implanted devices. Thus, the nanorobot architecture comprises also a single-chip RFID CMOS based sensor [36]. For the nanorobot active sonar communication frequencies may reach up to  $20\mu W @ 8Hz$  at resonance rates with 3V supply [37]. For brain aneurysm, a chemical nanosensor is embedded in the nanorobot to monitor NOS levels. From the last set of events recorded in pattern arrays, information can be reflected back by wave resonance. For nanorobot passive data transferring  $\sim 4.5 kHz$  frequency with approximate  $22\mu s$  delays are possible ranges for data communication.

In our molecular machine architecture, to successfully set an embedded antenna with 200nm size for the nanorobot RF communication, a small loop planar device is adopted as an electromagnetic pickup having a good matching on Low Noise Amplifier; it is based on gold nanocrystal with  $1.4nm^3$ , CMOS and nanoelectronic circuit technologies [29], [34]. Frequencies ranging from 1 to 200MHz can be successfully used for biomedical applications without any damage [34].

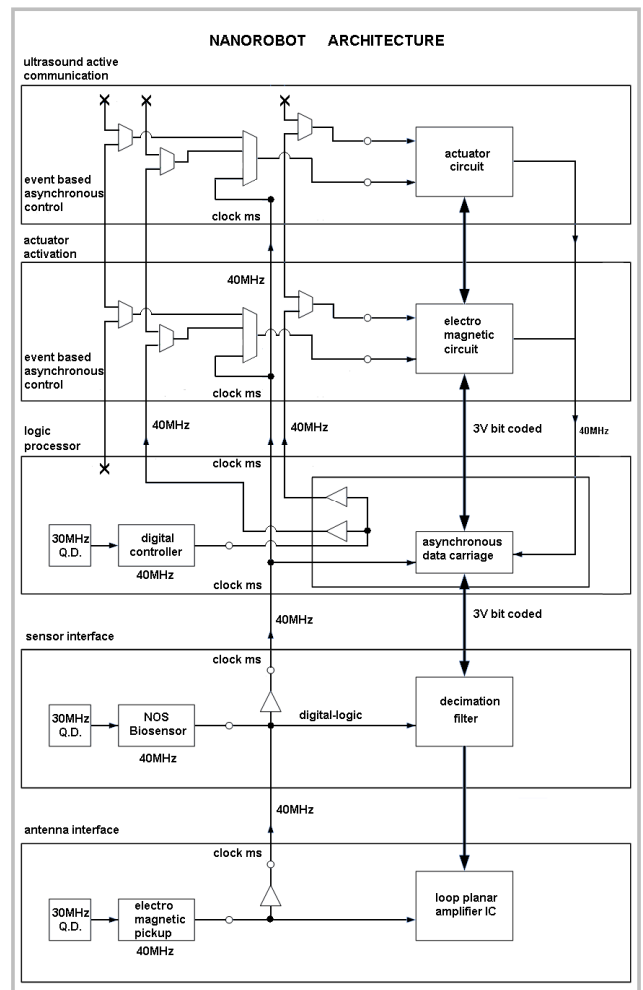

Fig. 4: Hardware integrated nanocircuit architecture.

IV. IMPLEMENTATION AND SIMULATION RESULTS

Nanorobots using chemical sensors as embedded nanoelectronics can be programmed to detect different levels of inducible Nitric Oxide Synthase (iNOS) pattern signals; the iNOS proteins serve as medical targets for early stages of aneurysm development (Fig. 2). In the NOS subgroups, while eNOS acts as a positive protein, the nNOS is generally related with neurodegenerative diseases, like Alzheimer and Parkinson, and can play a special role on endothelial cell degenerative changes [24]. In special, nNOS may result in negative effects with nitrosative stress, accelerating intracranial aneurysm rupture. Nanorobots as mobile medical devices injected through the bloodstream are used in our study; the medical 3D environment comprises clinical data based on main morphological parameters from patients with cerebral aneurysm (Fig. 3).

Integrated nanosensors, nanobioelectronics, and RF wireless communication [2] are incorporated the nanorobot model in order to inform changes of gradients for iNOS signals [25], assisting the doctors in decision process about taking any action required. The nanorobot model includes IC

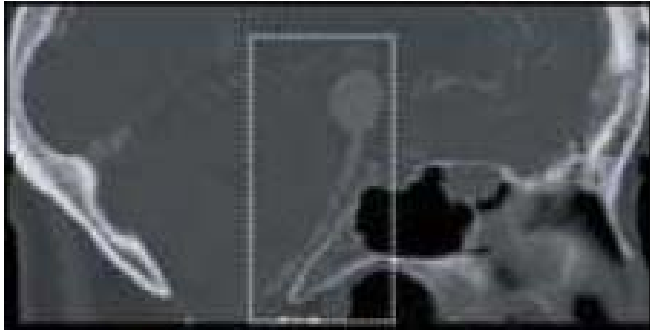

Fig. 5: Slice image from CT used for 3D reconstruction.

nanoelectronics, and the platform architecture can alternatively use cell phones for data transmission and coupling energy (Fig. 4). The nanorobot features a size of  $2\mu\text{m}$ , which permits it to operate freely inside the body. The computation is performed through embedded nanosensor; it is programmed for sensing and detection of NOS concentrations in the bloodstream. Due to background compounds, some detection occurs even without the NOS concentrations specified as aneurysm target. Therefore, for the chemical diffusion a capture rate  $\alpha$  is adopted for the aneurysm identification, given the radius  $R$  for a region with concentration as:

$$\alpha = 4\pi DR C. \quad (1)$$

$D$  represents the diffusion coefficient, and  $C$  is the chemical concentration [38]. With independent random motions for the molecules, detection over a time interval  $\Delta t$  is based on a Poisson process with mean value  $\alpha\Delta t$ . When objects occupy only a small fraction of the volume, the velocity at distance  $r$  from the center of the vessel is represented by:

$$w = 2v(1 - (r/(d/2))^2). \quad (2)$$

The velocity has a parabolic flow in relation to the cells. Considered a fluid moving with velocity  $v$  in the positive  $x$ -direction, it passing a plane containing a point of a chemical source produced at a rate  $Q$  (molecules per second) with diffusion coefficient  $D$ . Thus, diffusion equation is defined as:

$$D\nabla^2 C = v\partial C / \partial x, \quad (3)$$

with the boundary conditions of a steady point source at the origin, and no net flux across the boundary plane at  $y = 0$  [39]; the steady-state concentration  $C$  (molecules per  $\mu\text{m}^3$ ) is determined at point  $(x, y, z)$  by:

$$C(x, y, z) = \frac{Q}{2\pi Dr} e^{-v(r-x)/(2D)} \quad (4)$$

and  $r$  is the distance to the source:

$$r = \sqrt{x^2 + y^2 + z^2}. \quad (5)$$

Typical concentrations of NOS in bloodstream are less than  $1\text{M}$ , with signals having a lifetime of  $250\text{ms}$  [40]; therefore high precision and fast response are required for biosensors.

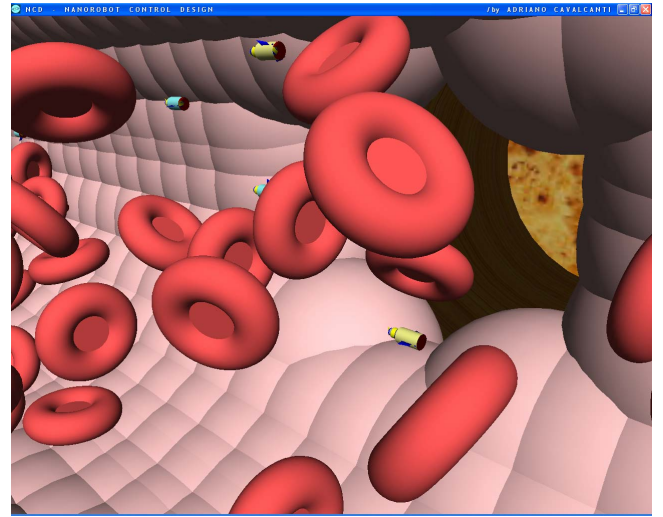

Fig. 6: Nanorobots flowing near the aneurysm detect NOS signal.

Furthermore, some false positive of NOS can occur quite easily due some positive functions of nitric oxide with semicarbazone (pNOS).

The nanorobot uses a RFID CMOS transponder system for in vivo positioning [36], with well established communication protocols to allow track information about the nanorobot position. The nanorobot exterior material consists of carbon metal nanocomposites [41], to which may be attached an artificial glycocalyx surface [42], that minimizes fibrinogen and other blood proteins adsorption or bioactivity, ensuring sufficient biocompatibility to avoid immune system attack [43]. Different molecule types are distinguished by a series of chemotactic sensors whose binding sites have a different affinity for each kind of molecule [10], [44]. These sensors can also detect obstacles which might require new trajectory for the nanorobot [45]. The nanorobot has sensory capabilities, allowing it to detect and identify the nearby possible obstacles in its environment, as well as the chemical signals for its task, such as NOS protein concentrations. A variety of sensors are possible [14], [22]. For instance, chemical detection can be very selective, e.g., for identifying various types of cells by markers [10].

The chemical detection in a complex dynamic environment is an important factor to consider for nanorobots in the task of interacting within the human body. In the nanorobot architecture, the integrated system comprises the engines for orientation, drive mechanisms, sensing and control. The main morphologic aspects related to brain aneurysm are taken for modeling the study of nanorobots sensing and interaction with blood fluid patterns in the deformed vessel (Fig. 5). A critical issue on cerebral aneurysm is to detect and locate the vessel dilation; the nanorobots need to track the aneurysm growth, before a subarachnoid hemorrhage happens (Fig. 6).

If the nanorobot's electrochemical sensor detects NOS in low quantities or inside normal gradients, it can generate a weak current lower than  $50\text{nA}$  (Fig. 7). In such case, the nanorobot ignores the NOS concentration, assuming it as expected levels of intracranial NOS. However, if the NOS patterns reach concentration higher than  $2\mu\text{l}$ , it activates the

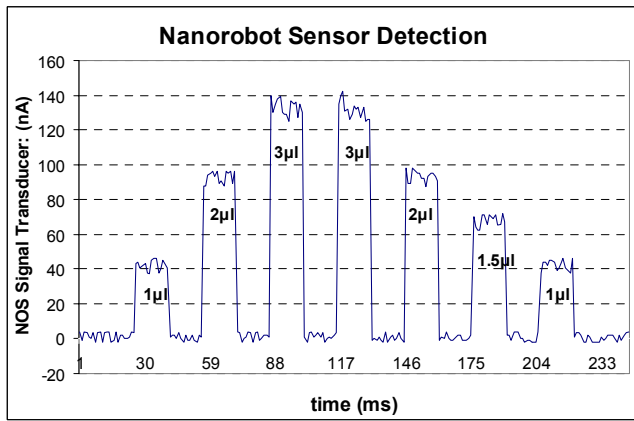

Fig. 7: Nanobiosensor activation.

embedded sensor generating electric current higher than 90nA. Every time it happens, the nanorobot is activated creating an electromagnetic signal back-propagated in the integrated system platform, which records the nanorobot's position when the signal happened. If in large proportions, these signals accurately indicate that the patient has an early stage of brain aneurysm, and also inform the doctors where the vessel bulb is located. To avoid noise distortions and achieve a higher resolution, the system considers a strong evidence of intracranial aneurysm, each time it received back-propagated signals from a total of 100 nanorobots. The nanorobots provide their respective positions for the moment they detected a high concentration of NOS (Figs. 8 and 9).

### V. CONCLUSION

Manufacturing methodologies are advancing progressively, which along with the use of 3D prototyping and computational simulation, help in the process of defining transducers and actuators design strategies relevant to medical nanorobotics. The research and development of nanorobots with embedded sensor device for medicine is an interesting subject, which can bring significant improvement for complex medical treatments as a high precision tool. This paper has presented a new strategy for the development of nanorobots, considering aspects of computation, and described an appropriate molecular machine prototype for medicine.

The nanorobot hardware architecture provided the main details on telemetric control and data transmission, with sensing capabilities to identify cerebral aneurysm at molecular levels. To enable early diagnosis of artery deformation, the nanorobot sensor based behavior used gradient changes of bloodstream signal components. The proposed hardware design using integrated nanocircuit architecture addresses major control interface requirements, and described the main parameters for inside body retrieving information.

In our study, the nanorobots have efficiently detected NOS signal occurrences, sending information about the positions where they identified abnormal vessel growth inside the brain. The study was based on clinical data, nanobioelectronics, and numerical analysis, with the architecture model proposed for *in vivo* use of nanorobots applied to intracranial therapy.

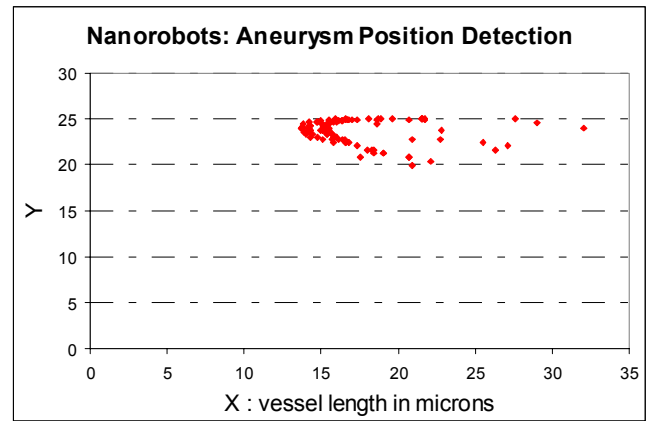

Fig. 8: Nanorobots detect NOS high concentration inside a small vessel within the intracranial bloodstream.

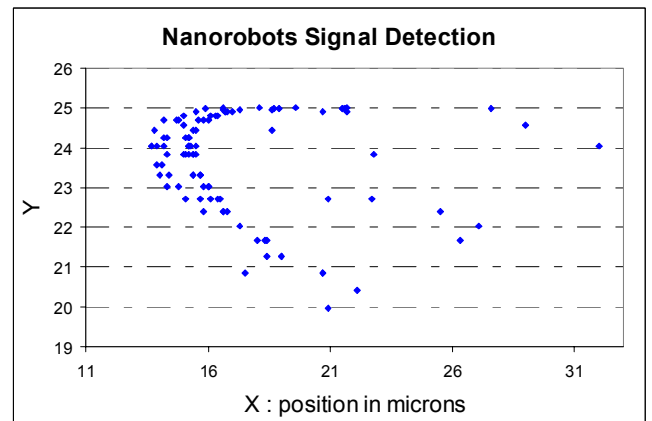

Fig. 9: Tracking the nanorobots' position - closer view.

### ACKNOWLEDGMENT

The authors thank Robert A. Freitas Jr., Tad Hogg, Luiz C. Kretly, and Marcello Rosa, for helpful comments.

### REFERENCES

- [1] S. P. Leary, C. Y. Liu, M. L. I. Apuzzo, "Toward the emergence of nanoneurosurgery: Part III - Nanomedicine: Targeted nanotherapy, nanosurgery, and progress toward the realization of nanoneurosurgery", *Neurosurgery*, vol. 58, no. 6, pp. 1009-1025 Jun. 2006.
- [2] A. Cavalcanti, B. Shirinzadeh, R. A. Freitas Jr., L. C. Kretly, "Medical Nanorobot Architecture Based on Nanobioelectronics", *Recent Patents on Nanotechnology*, Bentham Science, vol. 1, no. 1, pp. 1-10, Feb. 2007.
- [3] D. P. Sierra, N. A. Weir, J. F. Jones, "A Review of Research in the Field of Nanorobotics", Sandia Report, Office of Scientific and Technical Information, US Department of Energy, Oct. 2005.
- [4] A. Cavalcanti, R. A. Freitas Jr., "Nanorobotics Control Design: A Collective Behavior Approach for Medicine", *IEEE Transactions on Nanobioscience*, vol. 4, no. 2, pp. 133-140, Jun. 2005.
- [5] J. B. Mathieu, S. Martel, L. Yahia, G. Soulez, G. Beaudoin, "Preliminary Investigation of the Feasibility of Magnetic Propulsion for Future Microdevices in Blood Vessels", *Bio-Medical Materials and Engineering*, vol. 15, no. 5, pp. 367-374, 2005.

- [6] B. Behkam, M. Sitti, "Design Methodology for Biomimetic Propulsion of Miniature Swimming Robots", *Journal of Dynamic Systems, Measurement, and Control*, Trans. of the ASME, vol. 128, pp. 36-43, Mar. 2006.
- [7] J. Xi, J. J. Schmidt, C. D. Montemagno, "Self-assembled microdevices driven by muscle", *Nature Materials*, vol. 4, no. 2, pp. 180-184, Feb. 2005.
- [8] A. S. Lee, M. Mahapatro, D. A. Caron, A. A. G. Requicha, B. A. Stauffer, M. E. Thompson, C. Zhou, "Whole-cell sensing for a harmful bloom-forming microscopic alga by measuring antibody-antigen forces", *IEEE Transactions on Nanobioscience*, vol. 5, no. 3, pp. 149-156, Sep. 2006.
- [9] T. Fukuda, A. Kawamoto, F. Arai, H. Matsuura, "Steering mechanism and swimming experiment of micro mobile robot in water", *IEEE MEMS Micro Electro Mechanical Systems*, pp. 300-305, Jan. 1995.
- [10] R. A. Freitas Jr., "Nanotechnology, Nanomedicine and Nanosurgery", *International Journal of Surgery*, vol. 3, no. 12, pp. 1-4, Dec. 2005.
- [11] G. M. Patel, G. C. Patel, R. B. Patel, J. K. Patel, M. Patel, "Nanorobot: A versatile tool in nanomedicine", *Journal of Drug Targeting*, vol. 14, no. 2, pp. 63-67, Feb. 2006.
- [12] J. L. Reuss, R. S. Kirchner, "Method and system for remotely monitoring multiple medical parameters in an integrated medical monitoring system", 6364834US, Apr. 2002.
- [13] S. Ikeda, F. Arai, T. Fukuda, E. H. Kim, M. Negoro, K. Irie, I. Takahashi, "In Vitro Patient-Tailored Anatomical Model of Cerebral Artery for Evaluating Medical Robots and Systems for Intravascular Neurosurgery", *IEEE Int'l Conf. on Intelligent Robots and Systems*, pp. 1558-1563, Aug. 2005.
- [14] W. Xu, N. Vijaykrishnan, Y. Xie, M. J. Irwin, "Design of a Nanosensor Array Architecture", *ACM Proceedings of the 14th ACM Great Lakes symposium on VLSI*, pp. 298-303, Boston, Massachusetts, USA, Apr. 2004.
- [15] W. Rosner, L. Risch, T. Ramcke, "Circuit configuration having at least one nanoelectronic component and a method for fabricating the component", 6442042US, Aug. 2002.
- [16] J. G. Park, G. S. Lee, S. H. Lee, "Method of fabricating nano SOI wafer and nano SOI wafer fabricated by the same", 6884694US, Apr. 2005.
- [17] P. Couvreur, C. Vauthier, "Nanotechnology: Intelligent design to treat complex disease", *Pharmaceutical Research*, vol. 23, no. 7, pp. 1417-1450 Jul. 2006.
- [18] Q. Gao, M. J. Wolfgang, S. Neschen, K. Morino, T. L. Horvath, G. I. Shulman, X. Y. Fu, "Disruption of neural signal transducer and activator of transcription 3 causes obesity, diabetes, infertility, and thermal dysregulation", *Proc. Natl. Acad. Sci. USA*, vol. 101, no. 13, pp. 4661-4666, Mar 2004.
- [19] C. C. Roue, "Aneurysm liner", 6350270US, Feb. 2002.
- [20] P. B. Kubista, "Creating standard VHDL test environments", 6813751US, Nov. 2004.
- [21] M. J. Zhang, C. L. Sabharwal, W. Tao, T. J. Tarn, N. Xi, G. Li, "Interactive DNA sequence and structure design for DNA nanoapplications", *IEEE Transactions on Nanobioscience*, vol. 3, no. 4, pp. 286-292, Dec. 2004.
- [22] C. K. M. Fung, W. J. Li, "Ultra-low-power Polymer Thin Film Encapsulated Carbon Nanotube Thermal Sensors", *IEEE Conf. on Nanotechnology*, pp.158-160, Aug. 2004.
- [23] K. Bernstein, C. T. Chuang, R. Joshi, R. Puri, "Design and CAD Challenges in sub-90nm CMOS Technologies", *ACM Proc. of the Int'l Conf. on Computer Aided Design (ICCAD'03)*, pp. 129-136, 2003.
- [24] J. Kishimoto, N. Spurr, M. Liao, L. Lizhi, P. Emson, W. Xu, "Localization of brain nitric oxide synthase (NOS) to human chromosome 12", *Genomics*, vol. 14, no. 3, pp. 802-804, Nov. 1992.
- [25] S. Fukuda, N. Hashimoto, H. Naritomi, I. Nagata, K. Nozaki, S. Kondo, M. Kurino, H. Kikuchi, "Prevention of Rat Cerebral Aneurysm Formation by Inhibition of Nitric Oxide Synthase", *Circulation*, Vol. 101, no. 21, 2532-2538, May 2000.
- [26] NOS1, Nitric-oxide synthase, Human Protein Atlas, consulted in April 2007, <http://www.proteinatlas.org/search.php?chr=12>.
- [27] R. J. Crowley, "Carbon Nanotube Actuator", 7099071US, Aug. 2006.
- [28] J. Shi, Z. Wang, H. L. Li, "Selfassembly of gold nanoparticles onto the surface of multiwall carbon nanotubes functionalized with mercaptobenzene moieties", *Springer Journal of Nanoparticle Research*, vol. 8, no. 5, pp. 743-747, Oct. 2006.
- [29] K. H. Schifferli, J. J. Schwartz, A. T. Santos, S. Zhang, J. M. Jacobson, "Remote electronic control of DNA hybridization through inductive coupling to an attached metal nanocrystal antenna," *Nature* 415, pp. 152-156, Jan. 2002.
- [30] B. Ding, N. C. Seeman, "Operation of a DNA Robot Arm Inserted into a 2D DNA Crystalline Substrate", *Science*, vol. 314. no. 5805, pp. 1583-1585, Dec. 2006.
- [31] M. Jenkner, M. Tartagni, A. Hierlemann, R. Thewes, "Cell-based CMOS sensor and actuator arrays", *IEEE Journal of Solid-State Circuits*, vol. 39, no. 12, pp. 2431-2437, Dec. 2004.
- [32] L. S. Zheng, M. S. C. Lu, "A Large-Displacement CMOS-Micromachined Thermal Actuator with Capacitive Position Sensing", *Asian Solid-State Circuits Conf.*, pp. 89-92, Nov. 2005.
- [33] P. Mohseni, K. Najafi, S. Eliades, X. Wang, "Wireless multichannel biopotential recording using an integrated FM telemetry circuit," *IEEE Transactions on Neural Systems and Rehabilitation Engineering*, vol. 13, no. 3, pp. 263-271, Sep. 2005.
- [34] C. Sauer, M. Stanacevic, G. Cauwenberghs, N. Thakor, "Power Harvesting and Telemetry in CMOS for Implanted Devices", *IEEE Transactions on Circuits and Systems*, vol. 52, no. 12, pp. 2605-2613, Dec. 2005.
- [35] T. Eggers, C. Marscher, U. Marschner, B. Clasbrummel, R. Laur, J. Binder, "Advanced hybrid integrated low-power telemetric pressure monitoring system for biomedical application", *Proc. of Int'l Conf. on Micro Electro Mechanical Systems*, pp. 23-37, Miyazaki, Japan, Jan. 2000.
- [36] L. Ricciardi, I. Pitz, S. F. A. Sarawi, V. Varadan, D. Abbott, "Investigation into the future of RFID in biomedical applications", *Proc. of SPIE - The Int'l Society for Optical Engineering*, vol. 5119, pp. 199-209, Apr. 2003.
- [37] T. K. Horiuchi, R. E. Cummings, "A Time-Series Novelty Detection Chip for Sonar", *Int'l J. of Robotics and Automation*, ACTA Press, vol. 19, no. 4, pp. 171-177, 2004.
- [38] T. Hogg, "Coordinating Microscopic Robots in Viscous Fluids", *Autonomous Agents and Multi-Agent Systems*, Springer, vol. 14, no. 3, pp. 271-305, Jun. 2007.
- [39] A. Cavalcanti, T. Hogg, B. Shirinzadeh, H. C. Liaw, "Nanorobot Communication Techniques: A Comprehensive Tutorial", *IEEE ICARCV Int'l Conf. on Control, Automation, Robotics and Vision*, Grand Hyatt, Singapore, pp. 2371-2376, Dec. 2006.
- [40] M. Naware, A. Rege, R. Genov, M. Stanacevic, G. Cauwenberghs, N. Thakor, "Integrated Multi-Electrode Fluidic Nitric-Oxide Sensor and VLSI Potentiostat Array", *Proc. IEEE Int. Symp. Circuits and Systems (ISCAS'2004)*, Vancouver Canada, vol. 4, pp. 25-28, May, 2004.
- [41] R. J. Narayan, "Pulsed laser deposition of functionally gradient diamond-like carbon-metal nanocomposites", *Diamond and Related Materials*, vol. 14, no. 8, pp. 1319-1330 Aug. 2005.
- [42] R. E. Marchant, T. Zhang, Y. Qiu, M. A. Ruegsegger, "Surfactants that mimic the glycocalyx", 6759388US, Apr. 1999.
- [43] R. A. Freitas Jr., *Nanomedicine*, Vol. IIA: Biocompatibility, Landes Bioscience, 2003, <http://www.nanomedicine.com/NMIIA.htm>.
- [44] W. Lo, "High resolution semiconductor bio-chip with configuration sensing flexibility", 20060252143US, Nov. 2006.
- [45] A. Cavalcanti, "Assembly Automation with Evolutionary Nanorobots and Sensor-Based Control Applied to Nanomedicine", *IEEE Transactions on Nanotechnology*, vol. 2, no.2, pp. 82-87, Jun. 2003.